



CITY OF
TUCSON

ENVIRONMENTAL
SERVICES



November 15, 2010

VIA U.S. MAIL

Stakeholders Group

**Subject: City of Tucson Environmental Services
Draft Development Standard No. 6-01.0
Solid Waste and Recycle Disposal Collection and Storage**

Dear Ms. / Sir:

Please find enclosed the revised draft Development Standard No 6-01.0 for Solid Waste and Recycle Disposal, Collection and Storage. The revised draft includes comments obtained from the Stakeholders review meetings in July 2010 and the CDRC meeting in August 2010. In addition, the revised draft includes a section for off street parking when recycle and solid waste enclosures are included in the downtown development zone and guidelines for calculating annual waste generation based on a property's proposed use and square footage.

To set up a meeting to discuss the revised draft or submit comments please contact Jeff Drumm at (520) 837-3713 or email him at Jeffrey.Drumm@tucsonaz.gov. Environmental Services (ES) plans on submitting the final standard to the City Managers Office in December for adoption as the new standard. Please submit all comments to ES by December 15, 2010.

Very truly yours,

A handwritten signature in black ink, appearing to read "Andrew H. Quigley".

Andrew H. Quigley
Director

AQ/JD/mv

Enclosure

Revised Draft Development Standard No. 6-01.0

cc: Patricia Gehlen, City of Tucson, Planning and Development Services
Nancy Petersen, City of Tucson, ES
Jeff Drumm, City of Tucson, ES

CITY OF TUCSON
DEVELOPMENT STANDARD NO. 6-01.0
SOLID WASTE DISPOSAL AND RECYCLE COLLECTION AND STORAGE

DRAFT
October 15, 2010

**SOLID WASTE AND RECYCLE DISPOSAL
COLLECTION AND STORAGE**

6-01.1.0	PURPOSE
6-01.2.0	DEFINITIONS
6-01.3.0	APPLICABILITY
6-01.4.0	ALL DEVELOPMENT
6-01.5.0	MULTI-FAMILY, COMMERCIAL, AND INDUSTRIAL DEVELOPMENT
6-01.6.0	SINGLE-FAMILY RESIDENTIAL DEVELOPMENT
6-01.7.0	SPECIAL SERVICES
6-01.8.0	LIST OF EXHIBITS AND FIGURES

6-01.0.0 SOLID WASTE AND RECYCLE DISPOSAL

6-01.1.0 PURPOSE - The following Standards have been established for solid waste and recycle materials collection, storage, and disposal. The standards shall serve as guidelines for safe and efficient solid waste and recycling service.

To enhance the City of Tucson (COT) appearance, by implementing standards for the collection and storage of solid waste and recycle containers.

Establish dimensional requirements for container enclosures, accessibility and maneuvering space for collection vehicles.

To promote the recycling of materials generated by the COT residential, commercial, and industrial communities.

6-01.2.0 DEFINITIONS - Definitions for words used in this Standard are found below, in the Tucson City Code (TCC) Chapter 15, in the Development Standards Glossary, or in Sec. 6.2.0 of the Tucson Land Use Code (LUC).

APC, Automated Plastic Containers

ASL, Automated Side Loading service vehicle

PAAL, Parking Area Access Lane

CC&R, Covenants, Conditions, and Restrictions

ES, Environmental Services

CITY OF TUCSON
DEVELOPMENT STANDARD NO. 6-01.0
SOLID WASTE DISPOSAL AND RECYCLE COLLECTION AND STORAGE

6-01.3.0 APPLICABILITY - These Standards apply to all new construction and new service within the COT including the remodeling of existing sites as specified by the COT LUC, Section 3.3.3.12.

6-01.4.0 ALL DEVELOPMENT

4.1 General

- A. Details from this Standard shall be shown on the plan graphically and by written notes.
- B. A note specifying the anticipated method of collection and frequency based on the calculated tonnage from Table1 for the intended use.
- C. All solid waste and recycle metal containers storage areas shall be screened from public view, and from adjacent developments.
- D. APC's shall be allowed for solid waste and recycle collection for volumes not greater than 190 gallons per week, 95 gallons for solid waste and 95 gallons for recycle. Metal container service will be required when the waste stream calculation exceeds 190 gallons per week.
- E. Solid waste and recycle container enclosures built into property walls must comply with horizontal and vertical clearances as stated in this Development Standard.
- F. Properties without sufficient space for on-site collection and storage of solid waste and recycle containers shall be evaluated for service on a case by case basis. Examples of enclosures for metal containers are shown in the Exhibits and Figures of Section 6-01.9.0 of this Standard.
- G. Use of APC's for multi-family, commercial, or industrial development requires prior approval from ES.
- H. Each residential development as defined in TCC Chapter 15, require on-site solid waste and recycle collection services, must contact ES to establish services.
- I. Off-street parking may be reduced for existing development when trash and recycling enclosures are provided per Sec. 3.3.5.4.

CITY OF TUCSON
DEVELOPMENT STANDARD NO. 6-01.0
SOLID WASTE DISPOSAL AND RECYCLE COLLECTION AND STORAGE
6-01.5.0 MULTI-FAMILY, COMMERCIAL, AND INDUSTRIAL DEVELOPMENT

5.1 General

- A. New projects and the remodeling of existing sites (including mobile home parks) consisting of three (3) or more dwelling units shall provide centralized on-site solid waste and recycling collection service access within the tract. Utilization of individual containers (APC's) for three (3) or more new dwelling units requires approval by ES on a case by case evaluation of the proposed point of collection for the projects.
- B. All containers require enclosures with gates. Containers shall be stored in their enclosure when not being serviced and containers must be leak proof.
- C. The locations of walls, fences, hedges, or landscaped buffer areas that are designed to reduce noise and enhance the aesthetics at the point of the solid waste and recycling collection shall be shown on the plan.
- D. Each development or business requiring on-site solid waste collection service shall comply with providing a minimum of two (2) single or one (1) double wide enclosure(s) to accommodate for both solid waste and recycling collection. Additional enclosures may be required based on the nature and volume of waste generated by the development/business in comparison with current standards and practices.
- E. Where a development is intending to provide centralized storage and collection to serve multiple buildings, tenants, or businesses, a general note must be included within the plan stating "A single property owner, property management company, or association will be responsible for the management and maintenance of the solid waste collection services and storage area(s) for all development/business occupants."

5.2 Enclosure Specifications

- A. Enclosure walls shall be masonry constructed as shown in Figure 2.
- B. Vertical steel pipes (bollards) are required within the enclosure as wall protection. The inside edge of the bollard shall be a minimum of one (1) foot inside the inside surface of the rear and side walls of the enclosure to prevent the container from damaging the walls of the enclosure. (See Figure 3A & 3B)
- C. The enclosure shall have a minimum ten (10) foot by ten (10) foot unobstructed interior space per container within the bollards.(See Figure 3A & 3B)
- D. Enclosures are to have gates with latches to prevent unauthorized access and to visually screen the container. Gates are to be mounted to a post fastened and secured on the front face of the enclosure wall(s).

CITY OF TUCSON
DEVELOPMENT STANDARD NO. 6-01.0
SOLID WASTE DISPOSAL AND RECYCLE COLLECTION AND STORAGE

- E. Enclosure gates shall be painted to match or compliment the enclosure walls.
- F. Enclosure and gates must have a minimum unobstructed opening of twelve (12) feet (See Figure 3A & 3B). The gates must be securable in both the closed and open positions.
- G. A concrete service apron shall be constructed six (6) inches thick with a minimum of two (2) percent slope away from the enclosure. To prevent storm water from collecting in front of the enclosure gates. (See Figures 3A & 3B)
- H. The enclosure shall have a concrete slab six (6) inches thick, and the concrete shall have a design strength of 3000 psi with welded wire fabric, (6x6,10x10) reinforcement.
- I. Stationary compactor units shall be screened from adjacent properties and public right-of-way. Enclosure shall allow space to include recycle containers.
- J. Stationary roll-off compactor unit shall be placed on a pad of sufficient width to provide a two (2) foot clear area on each side of the unit. The overall length of the pad must be five (5) feet greater than the combined length of the compactor, receiving container, and recycle container. The lengths of the receiving containers will vary depending on the container's capacity.
- K. The pad shall be designed to contain liquids resulting from compactor seepage, and or spills during loading and servicing, including any fluids resulting from equipment malfunctions. (No liquids shall run off from the compactor enclosure pad).

5.3 Access and Maneuvering Standards

- A. Service access shall be from within the development.
- B. A minimum safe access and operational area of fourteen (14) feet by forty (40) feet, with a minimum vertical clearance of twenty-five (25) feet, shall be provided in front of each enclosure.
- C. An adequate and safe ingress/egress is required for the collection vehicle in each new project. On-site turnarounds for service vehicles are shown in Figure 6 and 7.
- D. Metal container locations shall be placed so that the collection vehicle does not have to back into the public right-of-way or into moving traffic.

CITY OF TUCSON
DEVELOPMENT STANDARD NO. 6-01.0
SOLID WASTE DISPOSAL AND RECYCLE COLLECTION AND STORAGE

- E. Maneuvering requirements - the minimum turning radiuses required for collection vehicle to service metal containers shall be (36) feet for the inside rear wheels radius and (50) feet for the outside front bumper as illustrated on Figure 7. At any structure or vehicle parking space there must be a minimum of three (3) feet of clearance between the collection vehicle and the maneuvering/turning radius.
- F. The maximum back-up distance for the collection vehicle shall be eighty (80) feet measured from the front of the collection vehicle.
- G. When the width and depth of the property to be developed is insufficient to provide service access from within the development, the enclosures may be located such that service access is from the adjacent public right-of-way with a forty-five (45) or thirty (30) degree angle of approach that allows service by the vehicle without the collection vehicle pulling completely off the public right-of-way. (Note: Off street service is not permitted from arterial or collector streets. (See Figure 1 & 4)
- H. Service vehicle will approach in-line with the enclosure; ten (10) feet of space must be provided in front of the enclosure for a vehicle to maneuver in order to service the containers. (See Figure 3A & 3B)
- I. Private streets must conform to Street Development Standard 3-01.0 to provide adequate access for the service vehicle, and be approved by Planning & Development Services.

5.4 Location Standards

- A. Containers shall not be stored on any public right-of-way, bike lane, sidewalk or other public access.
- B. Containers and enclosures shall not obstruct traffic line-of-sight visibility.
- C. Containers and enclosures shall not obstruct or block drainage.

5.5 Operational Standards

- A. The property owner shall be responsible for keeping the collection and storage areas free from obstructions, vegetation, any liquids spilled within storage enclosures.

CITY OF TUCSON
DEVELOPMENT STANDARD NO. 6-01.0
SOLID WASTE DISPOSAL AND RECYCLE COLLECTION AND STORAGE
6-01.6.0 SINGLE-FAMILY RESIDENTIAL DEVELOPMENT

6.1 General

- A. Curbside service in dedicated right-of-way or a PAAL using APC's and the ALS system is preferred for Single Family and Duplex Developments.
- B. New Single Family and Duplex Developments including mobile homes on individual lots fronting any major street (arterial or collector) will provide a frontage road, or on-site facilities for solid waste and recycling collection.
- C. 300-gallon APC solid waste service is based on three (3) residences per container. Service availability subject to ES approval.

6.2 Specifications

- A. The current ASL arm has an at-rest span of 8'-9". (See Figure 8)
- B. The ASL vehicle servicing containers of 90-gallons or less in size cannot be closer than two (2) feet from the container. (The arm will not secure the container if it is closer than two (2) feet.) (See Figure 8)
- C. A single 95-gallon or less APC requires a four (4) foot by eight and one-half (8½) foot clear area that is level and free of vegetation and other obstructions. For each additional container, an additional five and one-half (5½) feet is required. (See Figure 8)
- D. A single 300-gallon APC requires a six (6) foot by ten (10) foot clear area that is level and free of vegetation and other obstructions. For each additional container seven (7) feet more width is required. (See Figure 9)

6.3 Access and Maneuvering Standards

- A. The collection point shall be unobstructed by any other improvements such as mailboxes, light poles, fire hydrants, fencing, street signs, or landscaping.
- B. Alley access requires approval by ES. Alley shall have a minimum twenty (20) foot wide cross section, maintained with a twelve (12) foot wide clear travel lane.
- C. A twenty-five (25) foot minimum height clearance, free of any overhead obstructions (wires, branches, etc.), will be provided above the collection area. (The alley travel lane must have a minimum of fifteen (15) foot overhead clearance).

CITY OF TUCSON
DEVELOPMENT STANDARD NO. 6-01.0
SOLID WASTE DISPOSAL AND RECYCLE COLLECTION AND STORAGE
6.4 Location Standards for APC's, 95 gallons or less

- A. The standard collection point will be behind the curb in front of the premises in accordance with the Development Standards contained herein.
- B. The collection point shall be located outside the driveway space.
- C. Where sidewalks exist, APC's are to be placed in the buffer area between the curb and sidewalk. Placement shall be so as to not obstruct sidewalk traffic or bike lanes. There should be no obstruction within (15) feet of an APC set out for collection. (Common obstructions are cars, mailboxes, and light poles).
- D. APC's are permitted to remain adjacent to the street or behind the curb only on scheduled collection days.
- E. The service area cannot be greater than six (6) feet from the edge of the street or (if serviced from an alley) travel lane of the alley.
- F. The APC's, when stored, will be screened from view of adjacent properties and public right-of-way, and will be placed at an adequate distance from adjoining properties to prevent health-related impacts (odor, flies, etc.) to those properties.
- G. For residential collection that cannot be directly placed for collection in front of the residence, specific instructions on how and where the refuse/recycling APC's will be collected will be included in the subdivision's plat.

6-01.7.0 Special Services – In developments where proposed solid waste and recycle disposal service is not specified in these Standards (i.e., developments for the elderly or disabled), prior approval must be obtained from ES.

6-01.8.0 Waste Stream Calculation Guidelines

**CITY OF TUCSON
DEVELOPMENT STANDARD NO. 6-01.0
SOLID WASTE DISPOSAL AND RECYCLE COLLECTION AND STORAGE**

- A. Determine the square footage and uses for the proposed development. A separate calculation for each area that has a different use should be performed.

Calculation: Select the use that best describes the proposed usage, from Table 1 below. Then multiply the Floor Area (sq. ft) by the Annual Tons Generated for the usage selected.

Sample Calculation for Food Retail:

$$[\text{Area in sq. ft. } 3,000] \times [\text{Annual Waste Generated } 0.0057 \text{ tons/sq. ft.}] = \underline{17 \text{ Annual Tons Generated for specified usage.}}$$

Sample Calculation for an Office or Professional Services:

$$[\text{Area in sq. ft. } 2,000] \times [\text{Annual Waste Generated } 0.0013 \text{ tons/sq. ft.}] = \underline{2.6 \text{ Annual Tons Generated for specified usage}}$$

1,
is

Table 1: Annual Waste Generated Based On Proposed Usage	
1. Office, Professional Services or Small Retail Use	0.0013 tons/ sq. ft.
2. Industrial Use	0.0016 tons/ sq. ft.
3. Food Retail, Multi-Family, Large Commercial	0.0057 tons/ sq. ft.
4. Public Facility and Large Retail	0.00105 tons/ sq. ft.
5. School and Institution	0.00105 tons/ sq. ft.
6. Warehouses	0.00155 tons/ sq. ft.

(Table
Data

obtained from Fairfax County Virginia Solid Waste Stream Calculation Reference)

Estimated conversion factors for solid waste 3.0 lbs/gal. and 600 lbs/ cu.yds

- B. Determine the size and collection frequency required for the Annual Tons Generated for specified usage:

Sample Calculation for Food Retail Above: 17 Annual Tons Generated

$$[17 \text{ tons/year}] / [52 \text{ weeks /year}] = 0.329 \text{ tons /week}$$

$$[0.329 \text{ tons/week}] \times [2000 \text{ lbs/ton}] = 658 \text{ lbs/wk}$$

Size of container, $[658 \text{ lbs /wk}] / [3.0 \text{ lbs/gal}] = 219 \text{ gal/wk}$, this volume is greater than an APC of 95 gal/wk. Therefore, a metal container must be selected.

Selecting a 2 cubic yard container/wk = $[2 \text{ cu.yd./wk}] \times [202 \text{ gal/cu.yd}] = 404 \text{ gal/wk}$.

Therefore, 404 gal/wk will be adequate service for a Food Retail business of 3000 sq. ft. The 2 cubic yard metal container/wk is adequate.

CITY OF TUCSON
DEVELOPMENT STANDARD NO. 6-01.0
SOLID WASTE DISPOSAL AND RECYCLE COLLECTION AND STORAGE

Sample Calculation for an Office or Professional Services Above: 2.6 Annual Tons Generated
[2.6 tons/years] / [52 weeks / years] = 0.052 tons / week

[0.052 tons/week] x [2000 lbs/ton] = 100 lbs/wk

Size of container, [100 lbs /wk] / [3.0 lbs/gal] = 33.33 gal/wk, this volume is less than an APC of 95 gal/wk.

Therefore, a 95 gal/wk APC container will be adequate for specified usage.

6-01.9.0 LIST OF EXHIBITS AND FIGURES.

- Figure 1** - 45 Degree Enclosure 'Option' Off Residential Streets
- Figure 2** - Structural Design for Enclosure Walls
- Figure 3A** - Double Metal Container Enclosure (2 to 8 cubic yards)
- Figure 3B** - Single Metal Container Enclosure (2 to 8 cubic yards)
- Figure 4** - 30 & 45 Degree Enclosures off Alleys
- Figure 5** - 30 & 45 Degree Enclosures off PAAL's
- Figure 6** - Turnaround for Service Vehicles
- Figure 7** - Turning Radii/Turnaround for Service Vehicles
- Figure 8** - Specifications for 90 Gallon APC's
- Figure 9** - Specifications for 300 Gallon APC's

**CITY OF TUCSON
DEVELOPMENT STANDARD NO. 6-01.0
SOLID WASTE DISPOSAL AND RECYCLE COLLECTION AND STORAGE**

**CITY OF TUCSON
DEVELOPMENT STANDARD NO. 8-01.0
SOLID WASTE DISPOSAL**

SINGLE ENCLOSURE - FOR FRONT LOADING SERVICE

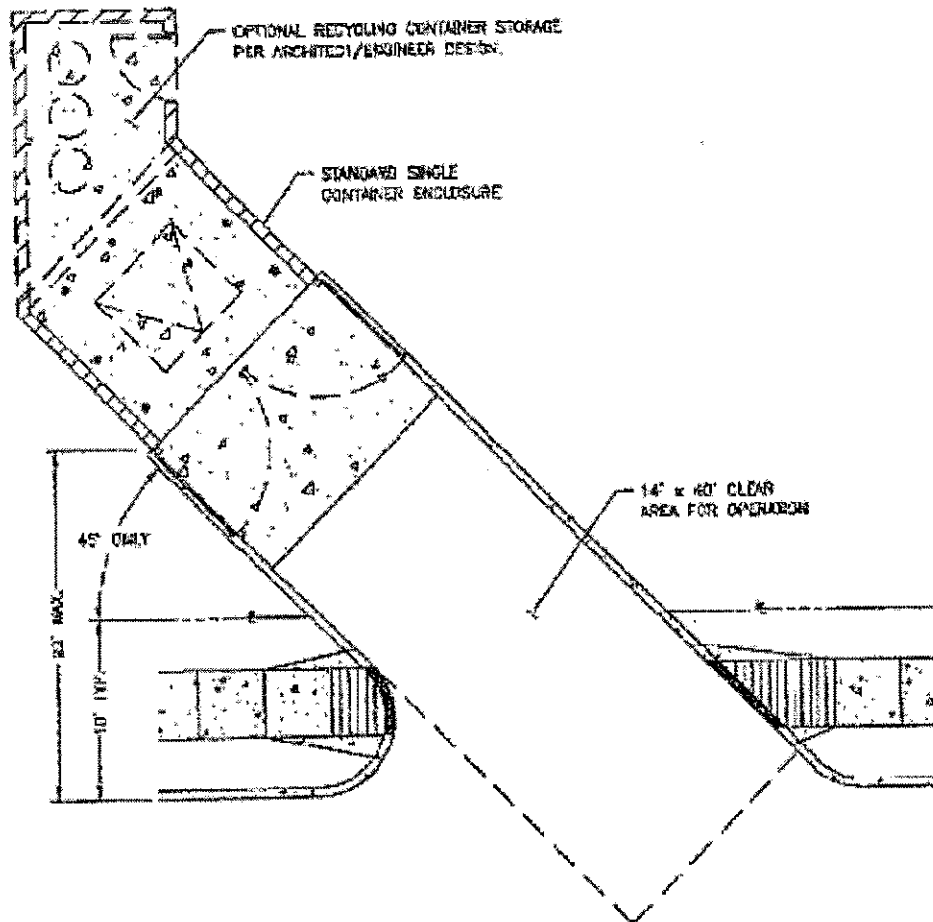

NOTE:

1. OPTIONS OF REFUSE PICKUP OFF NON-ARTERIAL OR COLLECTION TYPE STREETS TO BE APPROVED PRIOR TO PLAN SUBMITTAL.
2. CURBING AND SIDEWALK PER ARCHITECT/ ENGINEER DESIGN.
3. FOR DESIGN, TRUCK TURNING MOVEMENT FOR SERVICING THE CONTAINER SHOULD NOT PASS OVER THE CENTERLINE OF THE STREET.
4. SERVICE ONLY PROVIDED FOR RESIDENTIAL TYPE STREETS.
5. SERVICE ACCESS MAYBE COMBINED WITH COMPLEX ACCESS DRIVE AT ARCHITECT/ ENGINEER OPTION. PRIOR APPROVAL REQUIRED.

December 31, 2009 Figure 1 - 45 Degree Enclosure 'Option' Off Residential Streets

CITY OF TUCSON
DEVELOPMENT STANDARD NO. 6-01.0
SOLID WASTE DISPOSAL AND RECYCLE COLLECTION AND STORAGE

CITY OF TUCSON
DEVELOPMENT STANDARD NO. 6-01.0
SOLID WASTE DISPOSAL CONTAINMENT

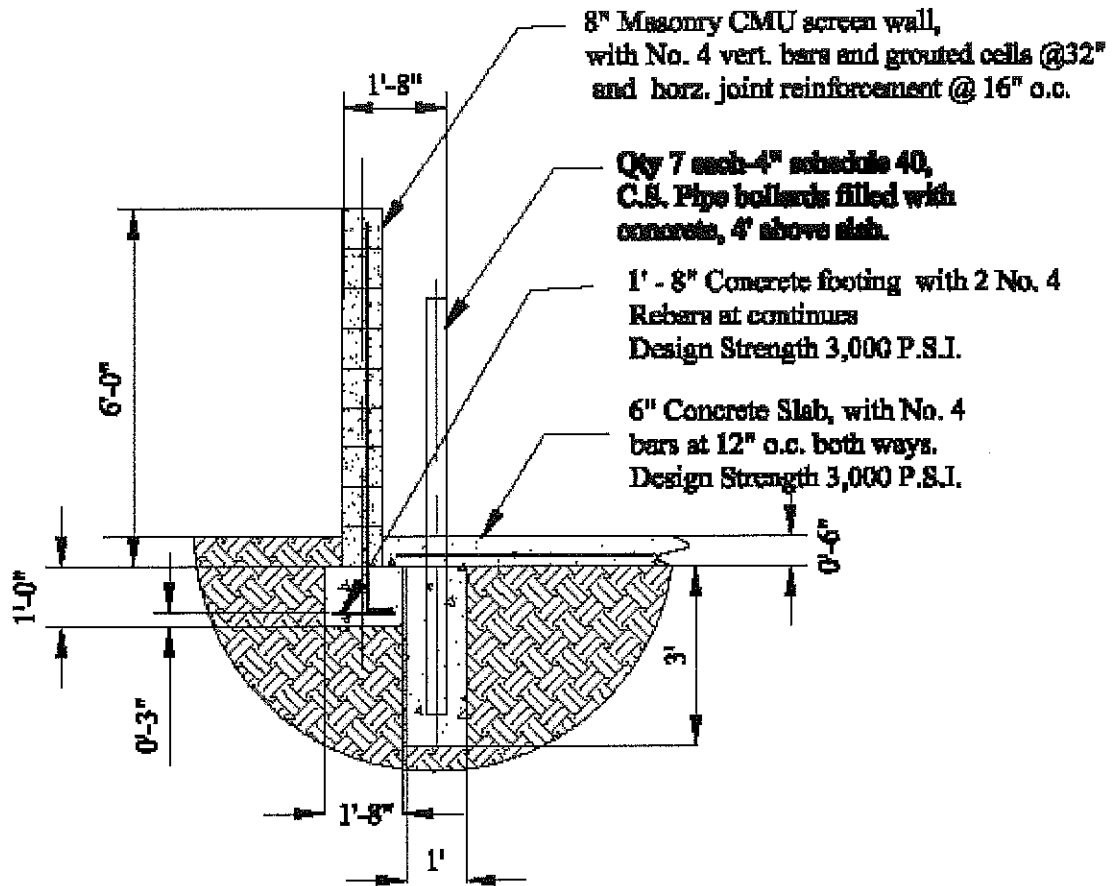

Structural Design for wall enclosure cross section (2 to 8 cubic yards)

December 31, 2009, FIGURE 2 - Structural Design for enclosure wall (2 to 8 cubic yards)

**CITY OF TUCSON
DEVELOPMENT STANDARD NO. 6-01.0
SOLID WASTE DISPOSAL AND RECYCLE COLLECTION AND STORAGE**

**CITY OF TUCSON
DEVELOPMENT STANDARD NO. 6-01.0
SOLID WASTE AND RECYCLABLE DISPOSAL CONTAINMENT**

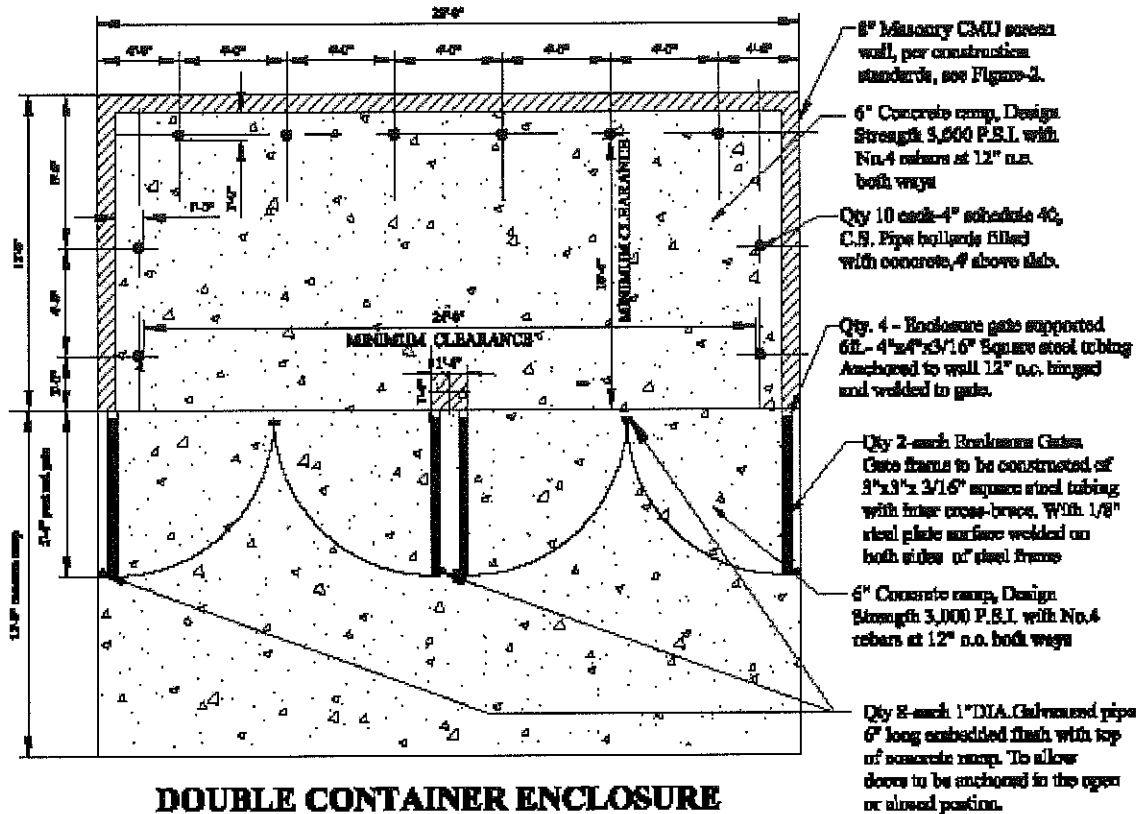

December 31, 2009, FIGURE -3A METAL CONTAINER ENCLOSURE (2 to 8 cubic yards)

CITY OF TUCSON
DEVELOPMENT STANDARD NO. 6-01.0
SOLID WASTE DISPOSAL AND RECYCLE COLLECTION AND STORAGE

**DEVELOPMENT STANDARD NO. 6-01.0
SOLID WASTE DISPOSAL CONTAINMENT**

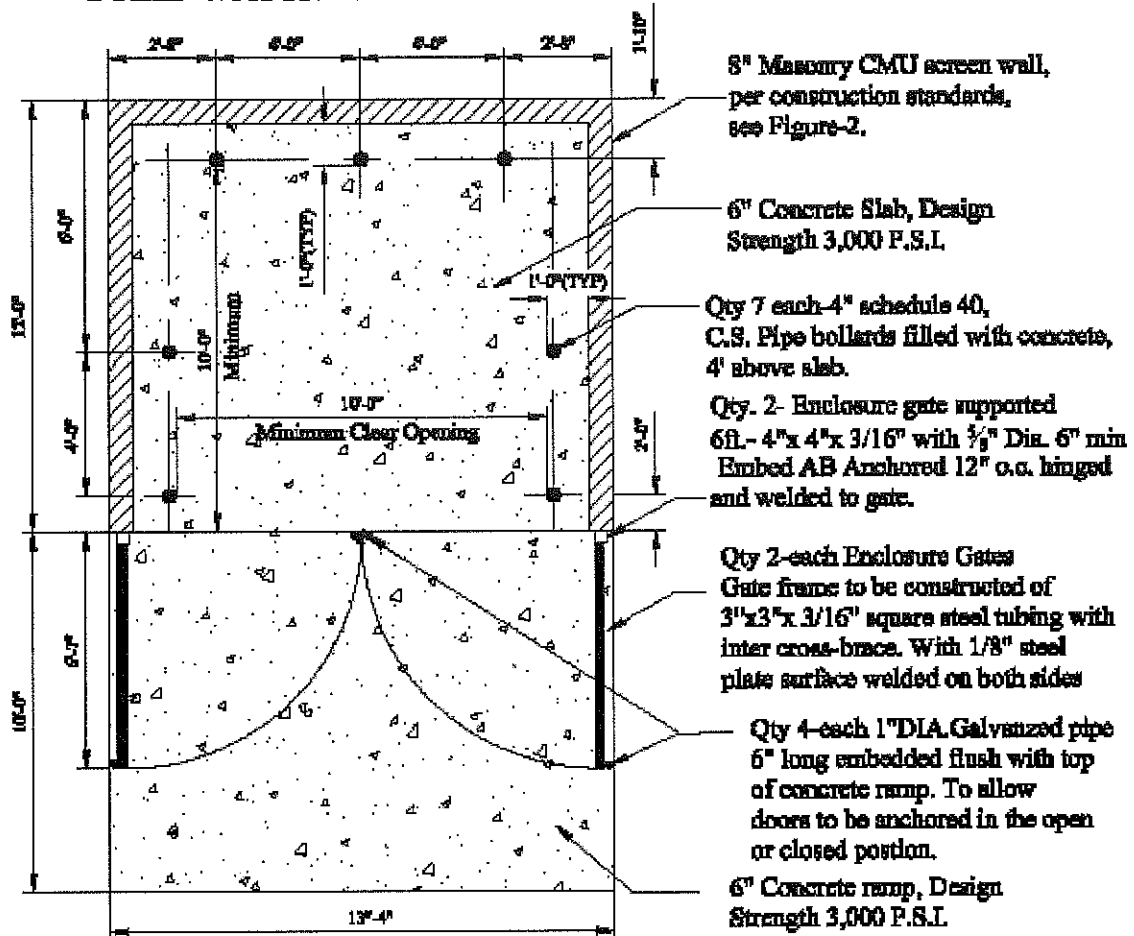

NOTES: SINGLE CONTAINER ENCLOSURE

1. Concrete ramp 14'x10'x6" slope shall be at 2%.
2. Concrete slab for enclosure shall slope at 1% to gate opening.
3. The inside clear width and length shall not be less than 10 ft.
4. For construction of multiple container enclosures, the clear width of 10 ft. is required for each container.
5. When necessary for personnel access a 3 ft wide doorway and steel frame door may be placed as required by the approved construction plan.
6. In front of enclosure a 14' x 40' clear area shall be required and must slope away from the enclosure at 2%.
7. All residential establishment must comply with the City of Tucson, Development Standards, Chapter-15

December 31, 2009, FIGURE 3B - METAL CONTAINER ENCLOSURE (2 to 8 cubic yards)

**CITY OF TUCSON
DEVELOPMENT STANDARD NO. 6-01.0
SOLID WASTE DISPOSAL AND RECYCLE COLLECTION AND STORAGE**

**CITY OF TUCSON
DEVELOPMENT STANDARD NO. 6-01.0
SOLID WASTE DISPOSAL**

**ENCLOSURE OF 20' ALLEY (SINGLE)
SCALE: 1"=20'**

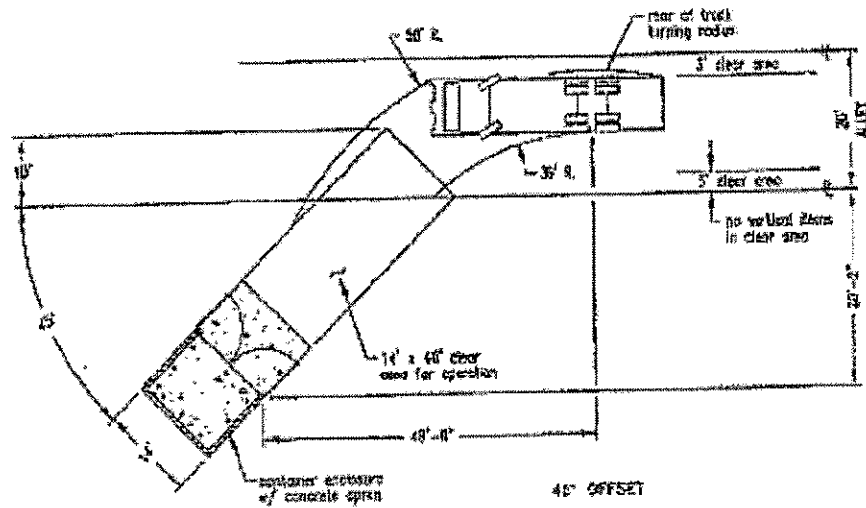
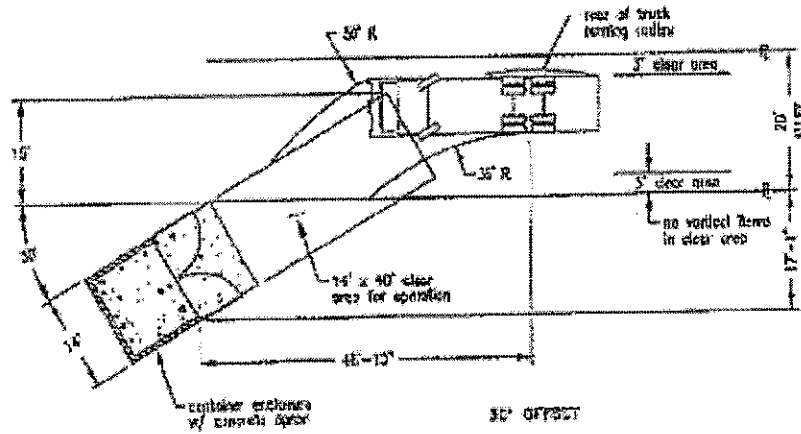

December 31, 2009 **Figure 4 - 30 & 45 Degree Enclosures of Alleys**

CITY OF TUCSON
 DEVELOPMENT STANDARD NO. 6-01.0
 SOLID WASTE DISPOSAL AND RECYCLE COLLECTION AND STORAGE

CITY OF TUCSON
 DEVELOPMENT STANDARD NO. 6-01.0
 SOLID WASTE DISPOSAL

ON-SITE TURNAROUND

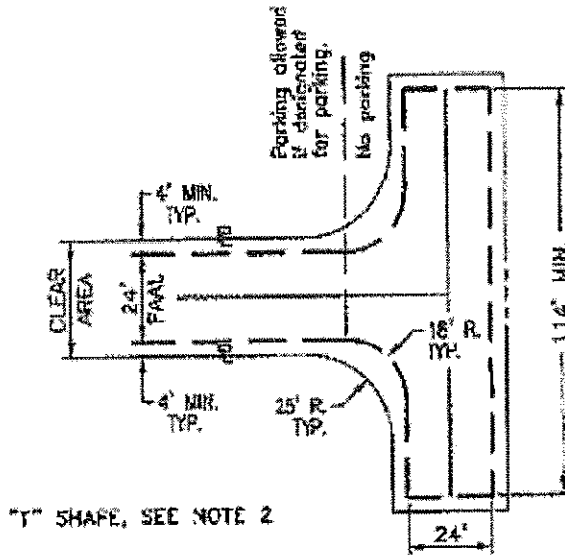

T SHAPE, SEE NOTE 2

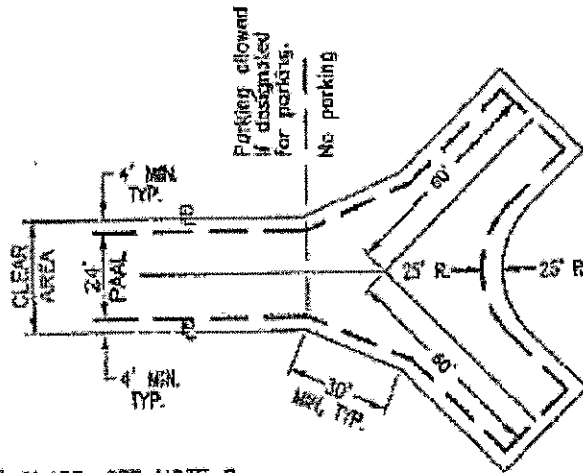

Y SHAPE, SEE NOTE 2

NOTE:

1. VERTICAL CURB SHALL BE REQUIRED IN THE TURNAROUND AREA.
2. IDENTICAL TO STREET DEVELOPMENT STANDARD 3.01.0, FIGURE 23.

December 31, 2009

Figure 6 - Turnaround for Service Vehicles

**CITY OF TUCSON
DEVELOPMENT STANDARD NO. 6-01.0
SOLID WASTE DISPOSAL AND RECYCLE COLLECTION AND STORAGE**

**CITY OF TUCSON
DEVELOPMENT STANDARD NO. 6-01.0
SOLID WASTE DISPOSAL**

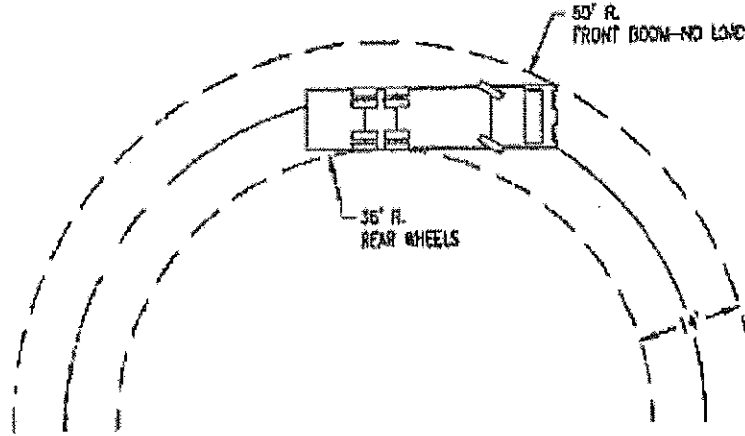

INDUSTRY STANDARD TURNING RADI FOR SERVICE VEHICLES
SCALE: 1"=20'

ON-SITE TURNAROUND

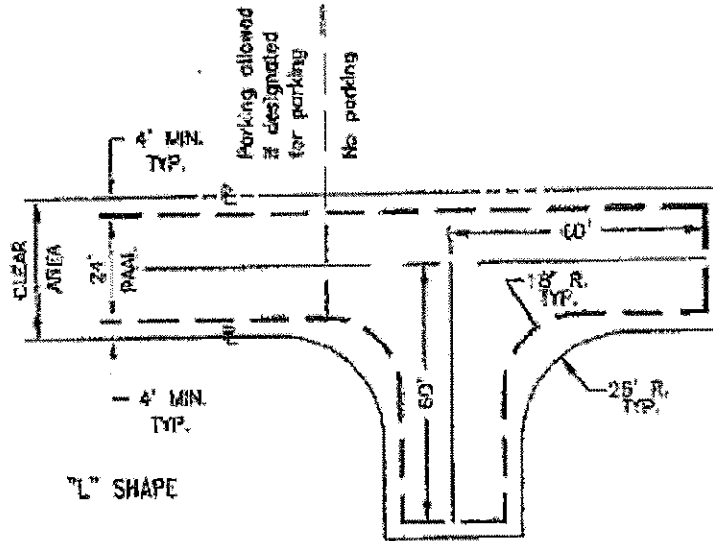

NOTE:

1. VERTICAL CURBS SHALL BE REQUIRED IN THE TURNAROUND AREA.

CITY OF TUCSON
DEVELOPMENT STANDARD NO. 6-01.0
SOLID WASTE DISPOSAL AND RECYCLE COLLECTION AND STORAGE

CITY OF TUCSON
DEVELOPMENT STANDARD NO. 6-01.0 SOLID
WASTE DISPOSAL CONTAINMENT

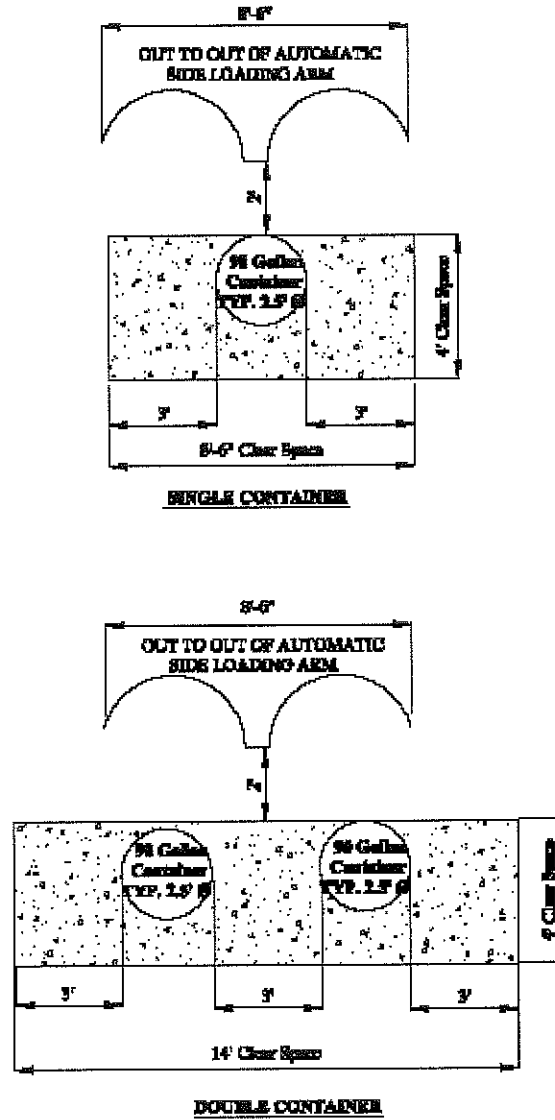

December 31, 2009, FIGURE-8, 90 gallon APC (Automated Plastic Container)

CITY OF TUCSON
DEVELOPMENT STANDARD NO. 6-01.0
SOLID WASTE DISPOSAL AND RECYCLE COLLECTION AND STORAGE

CITY OF TUCSON
DEVELOPMENT STANDARD NO. 6-01.0
SOLID WASTE DISPOSAL CONTAINMENT

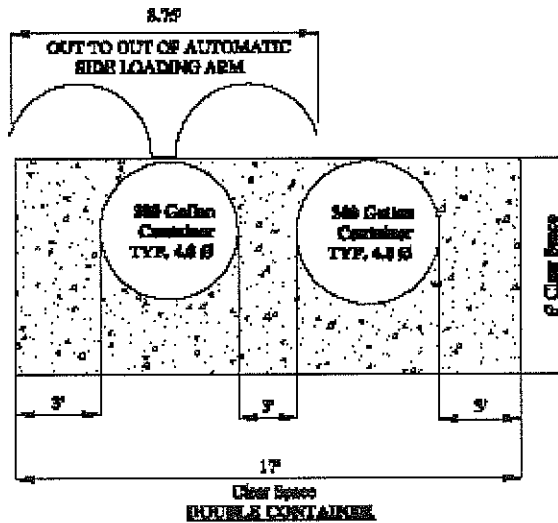
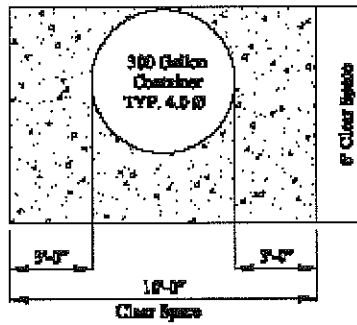
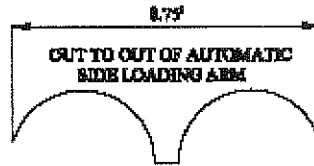

December 31, 2009, FIGURE-9, 300 gallon APC (AUTOMATED PLASTIC CONTAINER)